

# NUD3160

## Industrial Inductive Load Driver

This MicroIntegration™ part provides a single component solution to switch inductive loads such as relays, solenoids, and small DC motors without the need of a free-wheeling diode. It accepts logic level inputs, thus allowing it to be driven by a large variety of devices including logic gates, inverters, and microcontrollers.

### Features

- Provides Robust Interface between D.C. Relay Coils and Sensitive Logic
- Capable of Driving Relay Coils Rated up to 150 mA at 12 V, 24 V or 48 V
- Replaces 3 or 4 Discrete Components for Lower Cost
- Internal Zener Eliminates Need for Free-Wheeling Diode
- Meets Load Dump and other Automotive Specs
- Pb-Free Packages are Available

### Typical Applications

- Automotive and Industrial Environment
- Drives Window, Latch, Door, and Antenna Relays

### Benefits

- Reduced PCB Space
- Standardized Driver for Wide Range of Relays
- Simplifies Circuit Design and PCB Layout
- Compliance with Automotive Specifications



**ON Semiconductor®**

<http://onsemi.com>

### MARKING DIAGRAMS

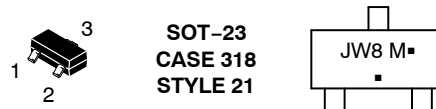

JW8 = Specific Device Code  
 M = Date Code  
 ■ = Pb-Free Package  
 (Note: Microdot may be in either location)

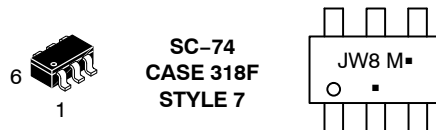

JW8 = Specific Device Code  
 M = Date Code  
 ■ = Pb-Free Package  
 (Note: Microdot may be in either location)

### ORDERING INFORMATION

Device	Package	Shipping†
NUD3160LT1	SOT-23	3000/Tape & Reel
NUD3160LT1G	SOT-23 (Pb-Free)	3000/Tape & Reel
NUD3160DMT1	SC-74	3000/Tape & Reel
NUD3160DMT1G	SC-74 (Pb-Free)	3000/Tape & Reel

†For information on tape and reel specifications, including part orientation and tape sizes, please refer to our Tape and Reel Packaging Specification Brochure, BRD8011/D.

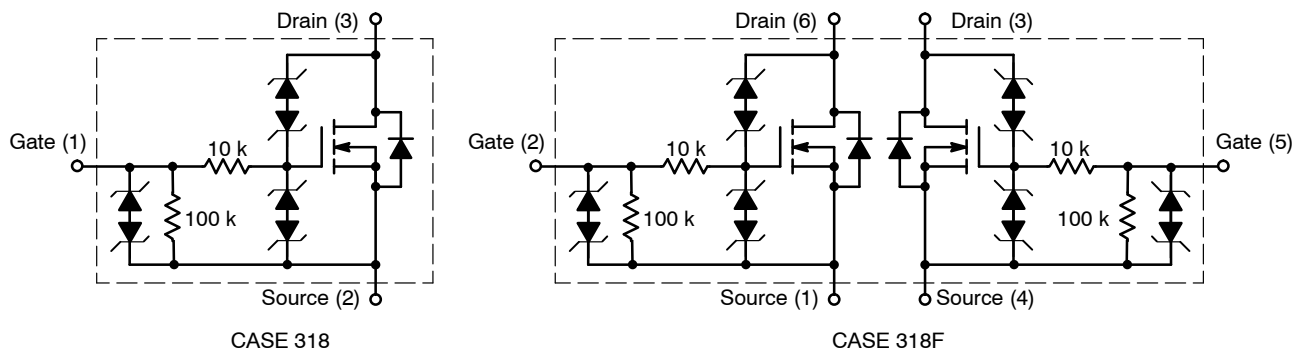

Figure 1. Internal Circuit Diagrams

# NUD3160

## MAXIMUM RATINGS (T<sub>J</sub> = 25°C unless otherwise specified)

Symbol	Rating	Value	Unit
V <sub>DSS</sub>	Drain-to-Source Voltage – Continuous (T <sub>J</sub> = 125°C)	60	V
V <sub>GSS</sub>	Gate-to-Source Voltage – Continuous (T <sub>J</sub> = 125°C)	12	V
I <sub>D</sub>	Drain Current – Continuous (T <sub>J</sub> = 125°C) Minimum copper, double sided board, T <sub>A</sub> = 80°C SOT-23 SC74 Single device driven SC74 Both devices driven 1 in <sup>2</sup> copper, double sided board, T <sub>A</sub> = 25°C SOT-23 SC74 Single device driven SC74 Both devices driven	158 157 132 ea  272 263 230 ea	mA
E <sub>Z</sub>	Single Pulse Drain-to-Source Avalanche Energy (For Relay's Coils/Inductive Loads of 80 Ω or Higher) (T <sub>J</sub> Initial = 85°C)	200	mJ
P <sub>PK</sub>	Peak Power Dissipation, Drain-to-Source (Notes 1 and 2) (T <sub>J</sub> Initial = 85°C)	20	W
E <sub>LD1</sub>	Load Dump Pulse, Drain-to-Source (Note 3) R <sub>SOURCE</sub> = 0.5 Ω, T = 300 ms (For Relay's Coils/Inductive Loads of 80 Ω or Higher) (T <sub>J</sub> Initial = 85°C)	60	V
E <sub>LD2</sub>	Inductive Switching Transient 1, Drain-to-Source (Waveform: R <sub>SOURCE</sub> = 10 Ω, T = 2.0 ms) (For Relay's Coils/Inductive Loads of 80 Ω or Higher) (T <sub>J</sub> Initial = 85°C)	100	V
E <sub>LD3</sub>	Inductive Switching Transient 2, Drain-to-Source (Waveform: R <sub>SOURCE</sub> = 4.0 Ω, T = 50 μs) (For Relay's Coils/Inductive Loads of 80 Ω or Higher) (T <sub>J</sub> Initial = 85°C)	300	V
Rev-Bat	Reverse Battery, 10 Minutes (Drain-to-Source) (For Relay's Coils/Inductive Loads of 80 Ω or more)	-14	V
Dual-Volt	Dual Voltage Jump Start, 10 Minutes (Drain-to-Source)	28	V
ESD	Human Body Model (HBM) According to EIA/JESD22/A114 Specification	2000	V

## THERMAL CHARACTERISTICS

Symbol	Rating	Value	Unit
T <sub>A</sub>	Operating Ambient Temperature	-40 to 125	°C
T <sub>J</sub>	Maximum Junction Temperature	150	°C
T <sub>STG</sub>	Storage Temperature Range	-65 to 150	°C
P <sub>D</sub>	Total Power Dissipation (Note 4) Derating above 25°C	SOT-23 225 1.8	mW mW/°C
P <sub>D</sub>	Total Power Dissipation (Note 4) Derating above 25°C	SC-74 380 3.0	mW mW/°C
R <sub>θJA</sub>	Thermal Resistance, Junction-to-Ambient Minimum Copper  300 mm <sup>2</sup> Copper	SOT-23 556 556 398  SOT-23 395 420 270	°C/W

1. Nonrepetitive current square pulse 1.0 ms duration.
2. For different square pulse durations, see Figure 12.
3. Nonrepetitive load dump pulse per Figure 3.
4. Mounted onto minimum pad board.

# NUD3160

## ELECTRICAL CHARACTERISTICS (T<sub>J</sub> = 25°C unless otherwise specified)

Characteristic	Symbol	Min	Typ	Max	Unit
<b>OFF CHARACTERISTICS</b>					
Drain to Source Sustaining Voltage (I <sub>D</sub> = 10 mA)	V <sub>BRDSS</sub>	61	66	70	V
Drain to Source Leakage Current (V <sub>DS</sub> = 12 V, V <sub>GS</sub> = 0 V) (V <sub>DS</sub> = 12 V, V <sub>GS</sub> = 0 V, T <sub>J</sub> = 125°C) (V <sub>DS</sub> = 60 V, V <sub>GS</sub> = 0 V) (V <sub>DS</sub> = 60 V, V <sub>GS</sub> = 0 V, T <sub>J</sub> = 125°C)	I <sub>DSS</sub>	–	–	0.5 1.0 50 80	μA
Gate Body Leakage Current (V <sub>GS</sub> = 3.0 V, V <sub>DS</sub> = 0 V) (V <sub>GS</sub> = 3.0 V, V <sub>DS</sub> = 0 V, T <sub>J</sub> = 125°C) (V <sub>GS</sub> = 5.0 V, V <sub>DS</sub> = 0 V) (V <sub>GS</sub> = 5.0 V, V <sub>DS</sub> = 0 V, T <sub>J</sub> = 125°C)	I <sub>GSS</sub>	–	–	60 80 90 110	μA
<b>ON CHARACTERISTICS</b>					
Gate Threshold Voltage (V <sub>GS</sub> = V <sub>DS</sub> , I <sub>D</sub> = 1.0 mA) (V <sub>GS</sub> = V <sub>DS</sub> , I <sub>D</sub> = 1.0 mA, T <sub>J</sub> = 125°C)	V <sub>GS(th)</sub>	1.3 1.3	1.8 –	2.0 2.0	V
Drain to Source On-Resistance (I <sub>D</sub> = 150 mA, V <sub>GS</sub> = 3.0 V) (I <sub>D</sub> = 150 mA, V <sub>GS</sub> = 3.0 V, T <sub>J</sub> = 125°C) (I <sub>D</sub> = 150 mA, V <sub>GS</sub> = 5.0 V) (I <sub>D</sub> = 150 mA, V <sub>GS</sub> = 5.0 V, T <sub>J</sub> = 125°C)	R <sub>DS(on)</sub>	–	–	2.4 3.7 1.8 2.9	Ω
Output Continuous Current (V <sub>DS</sub> = 0.3 V, V <sub>GS</sub> = 5.0 V) (V <sub>DS</sub> = 0.3 V, V <sub>GS</sub> = 5.0 V, T <sub>J</sub> = 125°C)	I <sub>DS(on)</sub>	150 100	200 –	– –	mA
Forward Transconductance (V <sub>DS</sub> = 12 V, I <sub>D</sub> = 150 mA)	g <sub>FS</sub>	–	400	–	mmho
<b>DYNAMIC CHARACTERISTICS</b>					
Input Capacitance (V <sub>DS</sub> = 12 V, V <sub>GS</sub> = 0 V, f = 10 kHz)	C <sub>iss</sub>	–	30	–	pf
Output Capacitance (V <sub>DS</sub> = 12 V, V <sub>GS</sub> = 0 V, f = 10 kHz)	C <sub>oss</sub>	–	14	–	pf
Transfer Capacitance (V <sub>DS</sub> = 12 V, V <sub>GS</sub> = 0 V, f = 10 kHz)	C <sub>rss</sub>	–	6.0	–	pf
<b>SWITCHING CHARACTERISTICS</b>					
Propagation Delay Times: High to Low Propagation Delay; Figure 2, (V <sub>DS</sub> = 12 V, V <sub>GS</sub> = 3.0 V) Low to High Propagation Delay; Figure 2, (V <sub>DS</sub> = 12 V, V <sub>GS</sub> = 3.0 V)  High to Low Propagation Delay; Figure 2, (V <sub>DS</sub> = 12 V, V <sub>GS</sub> = 5.0 V) Low to High Propagation Delay; Figure 2, (V <sub>DS</sub> = 12 V, V <sub>GS</sub> = 5.0 V)	t <sub>PHL</sub> t <sub>PLH</sub>  t <sub>PHL</sub> t <sub>PLH</sub>	– –  – –	918 798  331 1160	– –  – –	ns
Transition Times: Fall Time; Figure 2, (V <sub>DS</sub> = 12 V, V <sub>GS</sub> = 3.0 V) Rise Time; Figure 2, (V <sub>DS</sub> = 12 V, V <sub>GS</sub> = 3.0 V)  Fall Time; Figure 2, (V <sub>DS</sub> = 12 V, V <sub>GS</sub> = 5.0 V) Rise Time; Figure 2, (V <sub>DS</sub> = 12 V, V <sub>GS</sub> = 5.0 V)	t <sub>f</sub> t <sub>r</sub>  t <sub>f</sub> t <sub>r</sub>	– –  – –	2290 618  622 600	– –  – –	ns

# NUD3160

## TYPICAL WAVEFORMS

( $T_J = 25^\circ\text{C}$  unless otherwise specified)

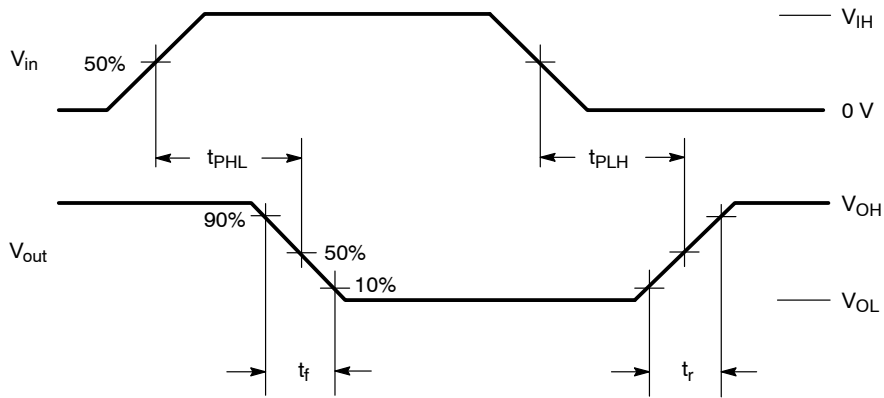

Figure 2. Switching Waveforms

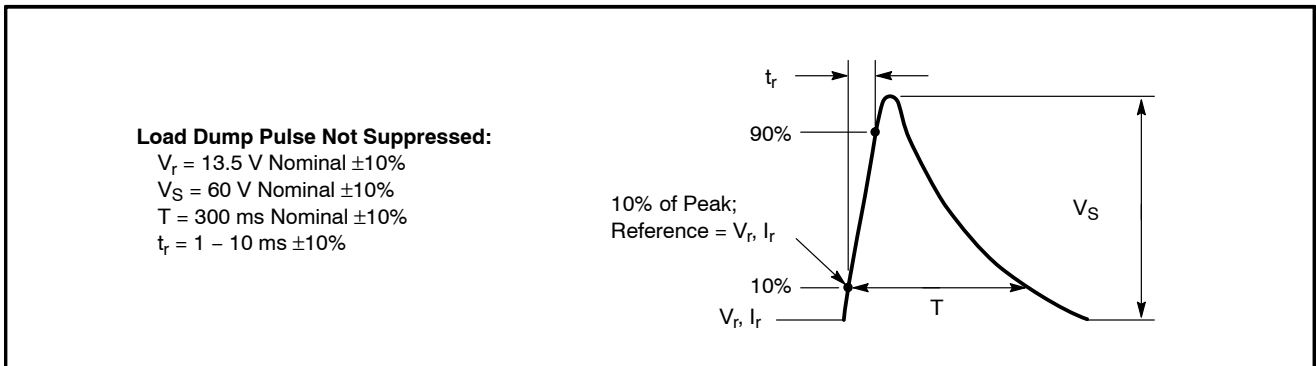
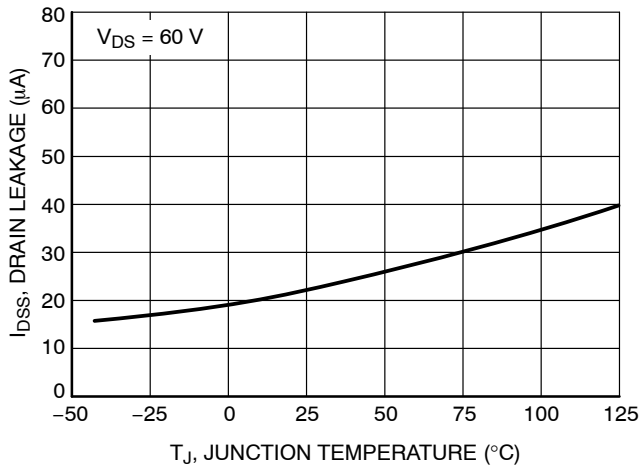

Figure 3. Load Dump Waveform Definition

# NUD3160

## TYPICAL PERFORMANCE CURVES

( $T_J = 25^\circ\text{C}$  unless otherwise specified)



**Figure 4. Drain-to-Source Leakage vs. Junction Temperature**

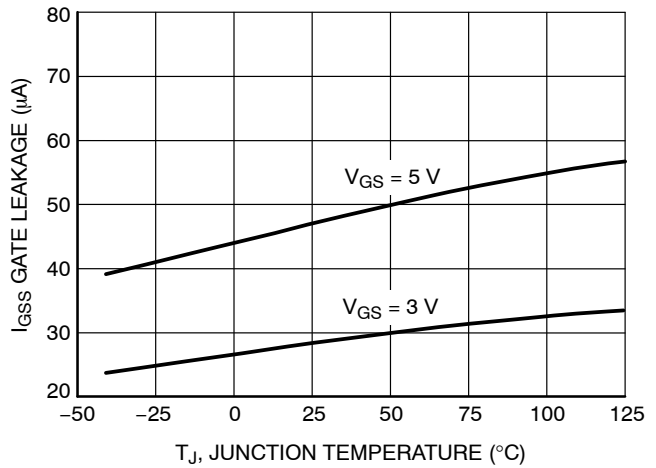

**Figure 5. Gate-to-Source Leakage vs. Junction Temperature**

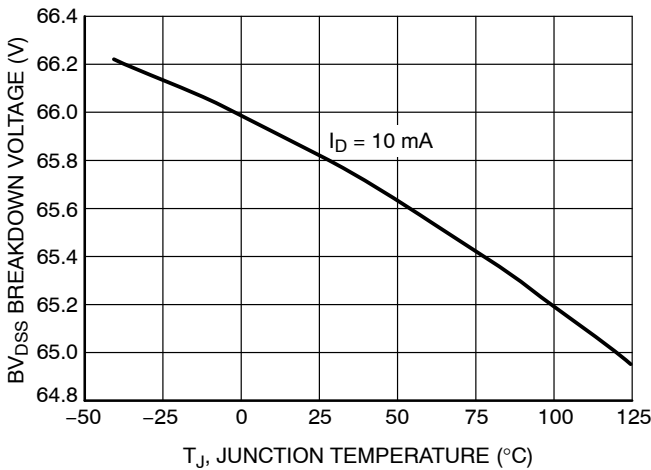

**Figure 6. Breakdown Voltage vs. Junction Temperature**

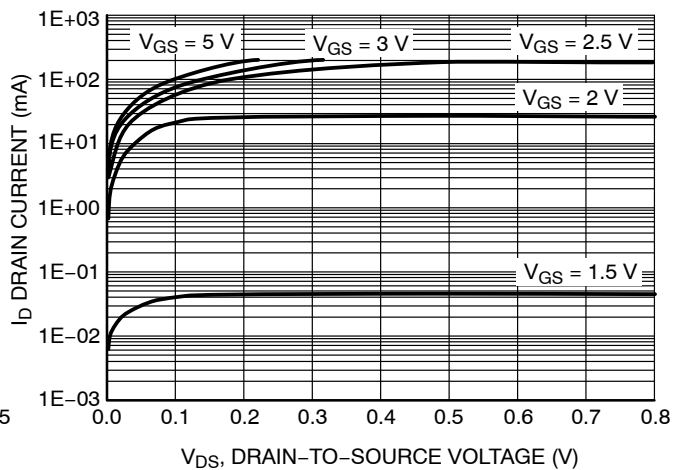

**Figure 7. Output Characteristics**

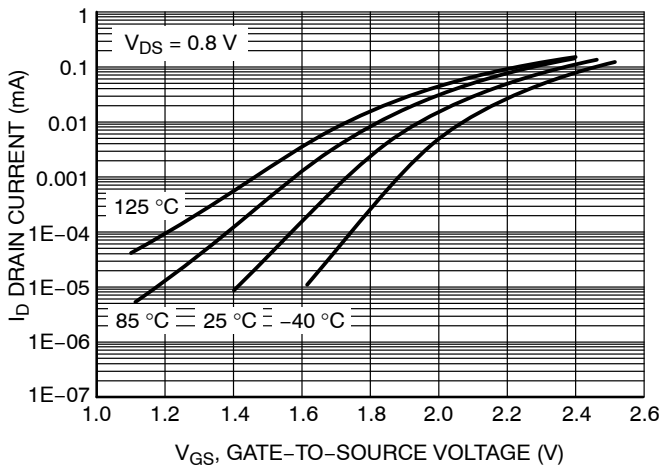

**Figure 8. Transfer Function**

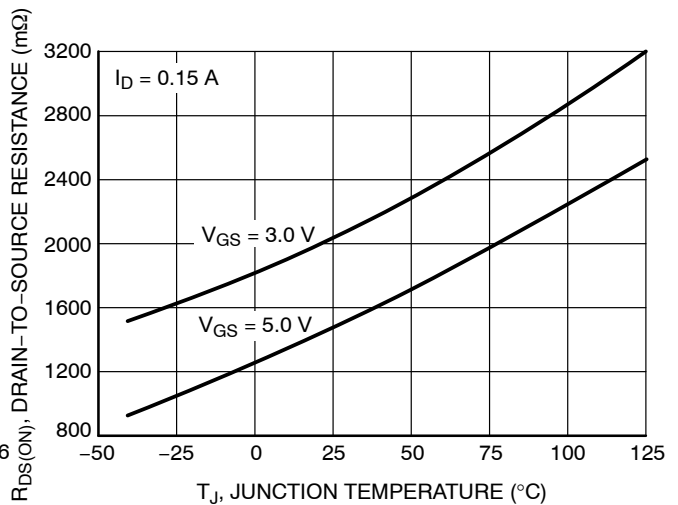
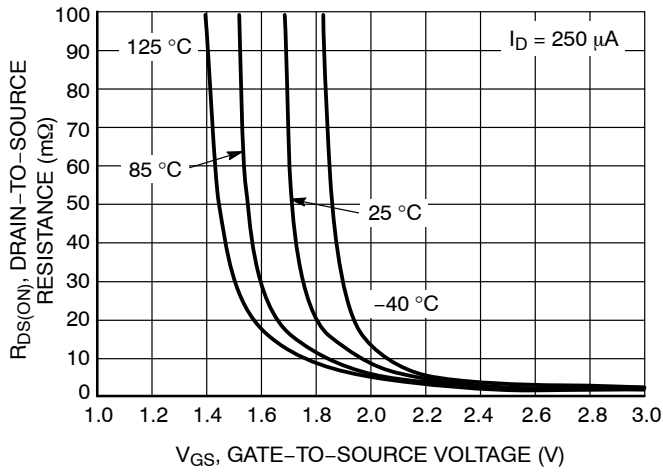

**Figure 9. On Resistance Variation vs. Junction Temperature**

# NUD3160

## TYPICAL PERFORMANCE CURVES

( $T_J = 25^\circ\text{C}$  unless otherwise specified)



**Figure 10. On Resistance Variation vs. Gate-to-Source Voltage**

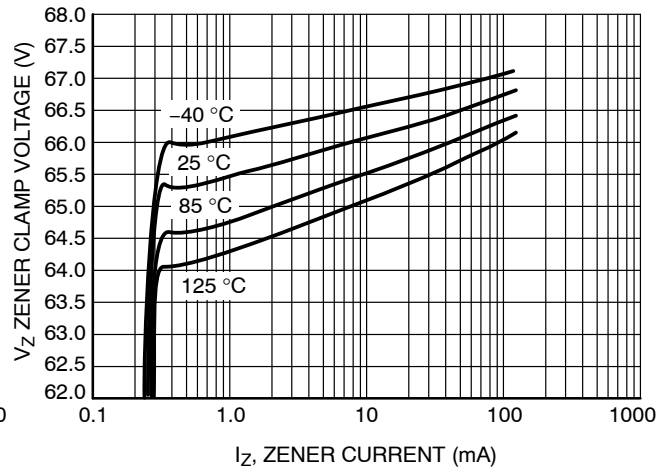

**Figure 11. Zener Clamp Voltage vs. Zener Current**

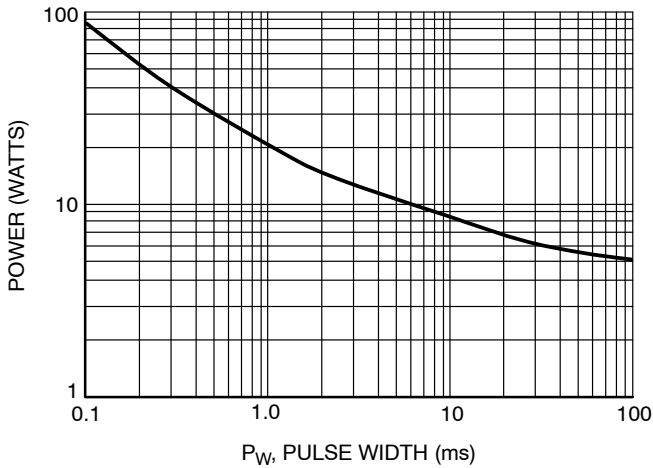

**Figure 12. Maximum Non-repetitive Surge Power vs. Pulse Width**

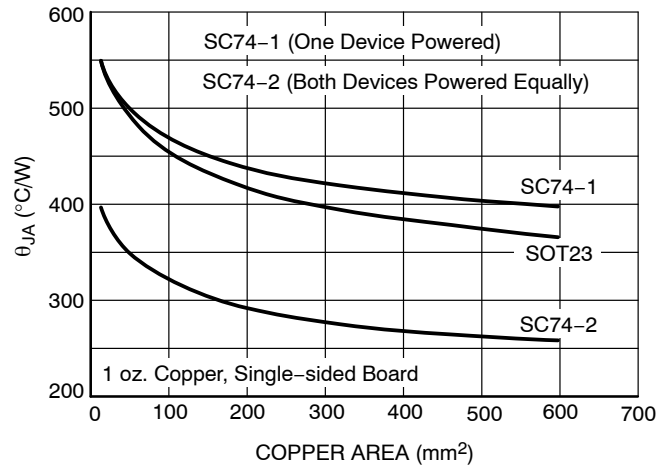

**Figure 13. Thermal Performance vs. Board Copper Area**

# NUD3160

## APPLICATIONS INFORMATION

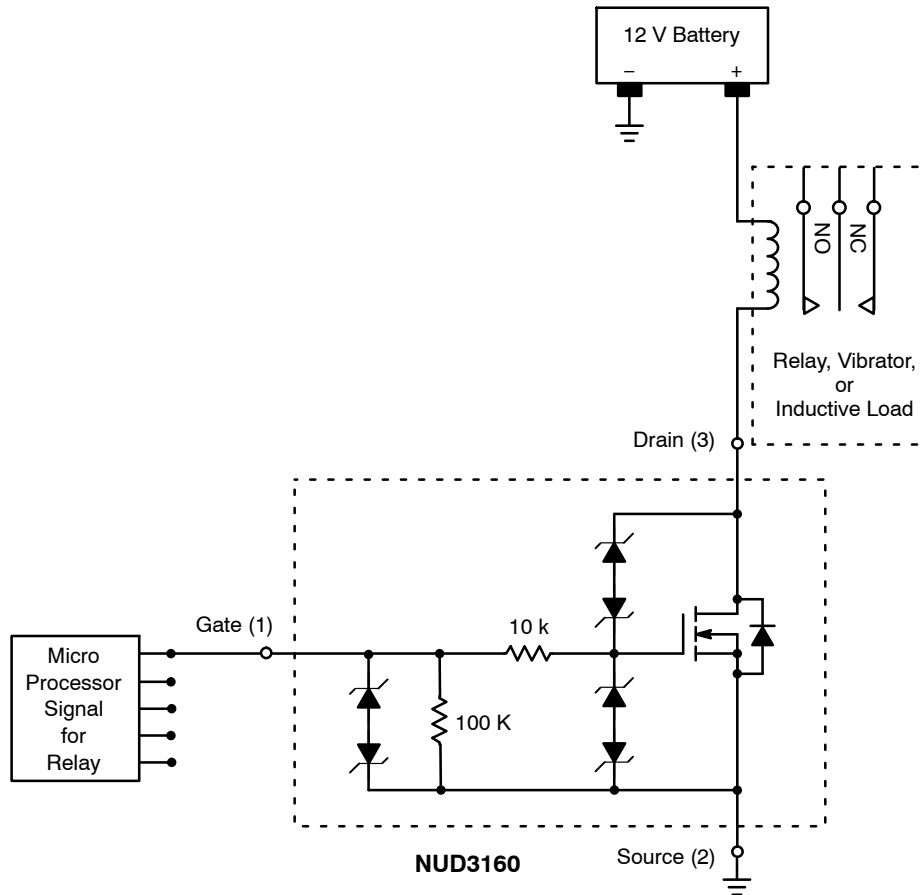
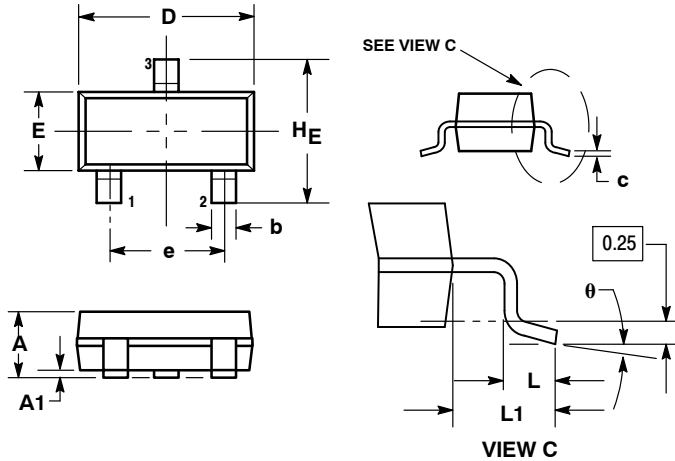

Figure 14. Applications Diagram

# NUD3160

## PACKAGE DIMENSIONS

SOT-23 (TO-236)  
CASE 318-08  
ISSUE AN



- NOTES:
1. DIMENSIONING AND TOLERANCING PER ANSI Y14.5M, 1982.
  2. CONTROLLING DIMENSION: INCH.
  3. MAXIMUM LEAD THICKNESS INCLUDES LEAD FINISH THICKNESS. MINIMUM LEAD THICKNESS IS THE MINIMUM THICKNESS OF BASE MATERIAL.
  4. 318-01 THRU -07 AND -09 OBSOLETE, NEW STANDARD 318-08.

DIM	MILLIMETERS			INCHES		
	MIN	NOM	MAX	MIN	NOM	MAX
A	0.89	1.00	1.11	0.035	0.040	0.044
A1	0.01	0.06	0.10	0.001	0.002	0.004
b	0.37	0.44	0.50	0.015	0.018	0.020
c	0.09	0.13	0.18	0.003	0.005	0.007
D	2.80	2.90	3.04	0.110	0.114	0.120
E	1.20	1.30	1.40	0.047	0.051	0.055
e	1.78	1.90	2.04	0.070	0.075	0.081
L	0.10	0.20	0.30	0.004	0.008	0.012
L1	0.35	0.54	0.69	0.014	0.021	0.029
HE	2.10	2.40	2.64	0.083	0.094	0.104

- STYLE 21:  
PIN 1. GATE  
2. SOURCE  
3. DRAIN

### SOLDERING FOOTPRINT\*

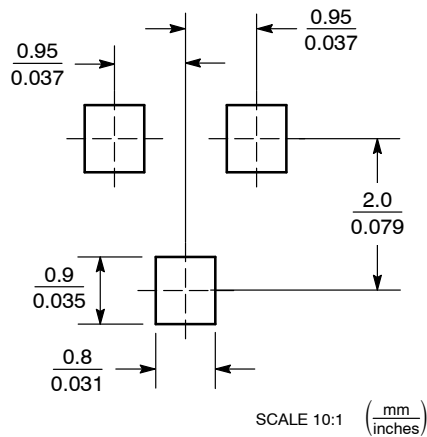

\*For additional information on our Pb-Free strategy and soldering details, please download the ON Semiconductor Soldering and Mounting Techniques Reference Manual, SOLDERRM/D.

# NUD3160

## PACKAGE DIMENSIONS

SC-74  
CASE 318F-05  
ISSUE L

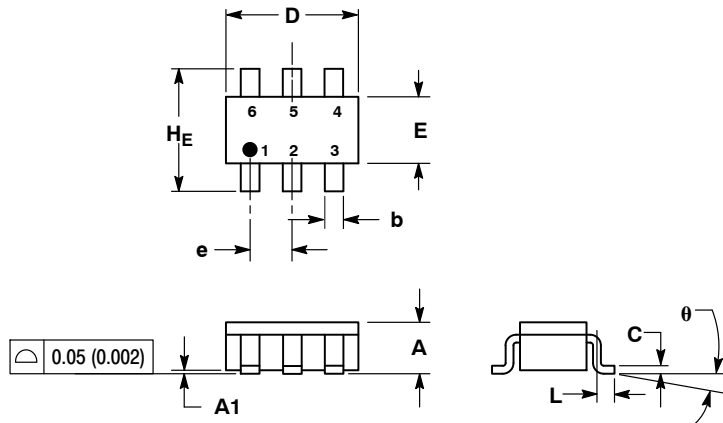

NOTES:

1. DIMENSIONING AND TOLERANCING PER ANSI Y14.5M, 1982.
2. CONTROLLING DIMENSION: INCH.
3. MAXIMUM LEAD THICKNESS INCLUDES LEAD FINISH THICKNESS. MINIMUM LEAD THICKNESS IS THE MINIMUM THICKNESS OF BASE MATERIAL.
4. 318F-01, -02, -03 OBSOLETE. NEW STANDARD 318F-04.

DIM	MILLIMETERS			INCHES		
	MIN	NOM	MAX	MIN	NOM	MAX
A	0.90	1.00	1.10	0.035	0.039	0.043
A1	0.01	0.06	0.10	0.001	0.002	0.004
b	0.25	0.37	0.50	0.010	0.015	0.020
c	0.10	0.18	0.26	0.004	0.007	0.010
D	2.90	3.00	3.10	0.114	0.118	0.122
E	1.30	1.50	1.70	0.051	0.059	0.067
e	0.85	0.95	1.05	0.034	0.037	0.041
L	0.20	0.40	0.60	0.008	0.016	0.024
HE	2.50	2.75	3.00	0.099	0.108	0.118
θ	0°	-	10°	0°	-	10°

STYLE 7:

- PIN 1. SOURCE 1
- 2. GATE 1
- 3. DRAIN 2
- 4. SOURCE 2
- 5. GATE 2
- 6. DRAIN 1

### SOLDERING FOOTPRINT\*

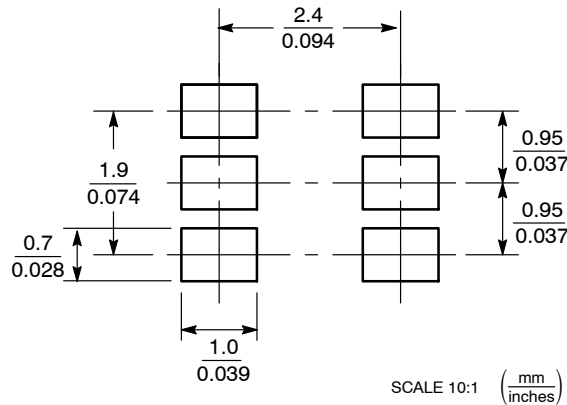

\*For additional information on our Pb-Free strategy and soldering details, please download the ON Semiconductor Soldering and Mounting Techniques Reference Manual, SOLDERRM/D.

Microlntegration is a trademark of Semiconductor Components Industries, LLC (SCILLC)

ON Semiconductor and are registered trademarks of Semiconductor Components Industries, LLC (SCILLC). SCILLC reserves the right to make changes without further notice to any products herein. SCILLC makes no warranty, representation or guarantee regarding the suitability of its products for any particular purpose, nor does SCILLC assume any liability arising out of the application or use of any product or circuit, and specifically disclaims any and all liability, including without limitation special, consequential or incidental damages. "Typical" parameters which may be provided in SCILLC data sheets and/or specifications can and do vary in different applications and actual performance may vary over time. All operating parameters, including "Typicals" must be validated for each customer application by customer's technical experts. SCILLC does not convey any license under its patent rights nor the rights of others. SCILLC products are not designed, intended, or authorized for use as components in systems intended for surgical implant into the body, or other applications intended to support or sustain life, or for any other application in which the failure of the SCILLC product could create a situation where personal injury or death may occur. Should Buyer purchase or use SCILLC products for any such unintended or unauthorized application, Buyer shall indemnify and hold SCILLC and its officers, employees, subsidiaries, affiliates, and distributors harmless against all claims, costs, damages, and expenses, and reasonable attorney fees arising out of, directly or indirectly, any claim of personal injury or death associated with such unintended or unauthorized use, even if such claim alleges that SCILLC was negligent regarding the design or manufacture of the part. SCILLC is an Equal Opportunity/Affirmative Action Employer. This literature is subject to all applicable copyright laws and is not for resale in any manner.

### PUBLICATION ORDERING INFORMATION

**LITERATURE FULFILLMENT:**  
Literature Distribution Center for ON Semiconductor  
P.O. Box 5163, Denver, Colorado 80217 USA  
**Phone:** 303-675-2175 or 800-344-3860 Toll Free USA/Canada  
**Fax:** 303-675-2176 or 800-344-3867 Toll Free USA/Canada  
**Email:** orderlit@onsemi.com

**N. American Technical Support:** 800-282-9855 Toll Free  
USA/Canada  
**Europe, Middle East and Africa Technical Support:**  
Phone: 421 33 790 2910  
**Japan Customer Focus Center**  
Phone: 81-3-5773-3850

**ON Semiconductor Website:** [www.onsemi.com](http://www.onsemi.com)  
**Order Literature:** <http://www.onsemi.com/orderlit>  
For additional information, please contact your local Sales Representative